

Modellname / Model name / Nom du modele / Modellnamn / Nome modello / Název modelu / Modelnaam / Ime modela / Numéro Modelo / Modell neve / Название модели / Názov modelu / Ime modela / Denumire model / Наименование на модела / Nazwa modelu

МОНТРЕАЛ

Modellnummer / Number / Numéro du modele / Numero / Номер на модела / modello / Číslo modelu / Modell száma / Eíslo modelu / Številka modela / Număr model / Broj modela / Modelnummer / Numer modelu

Type / Типо / Típus / Typ / Тип / Tip

ПЕНАЛ 1Д

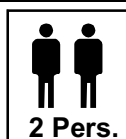
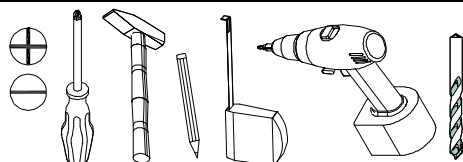
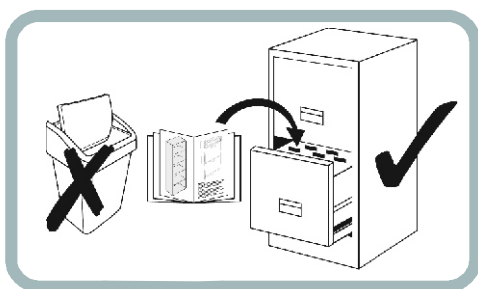
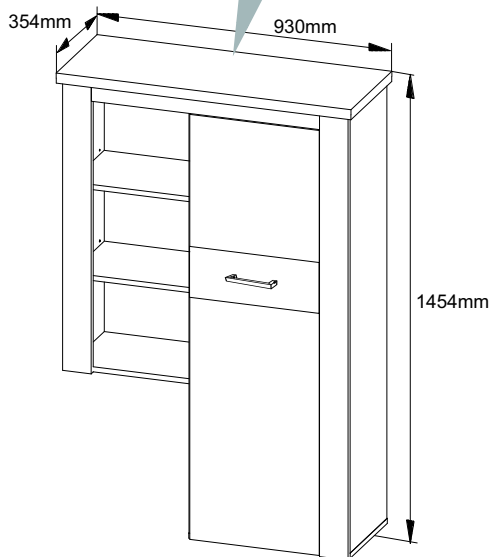
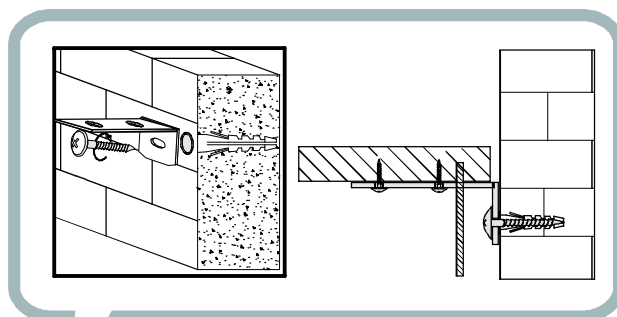
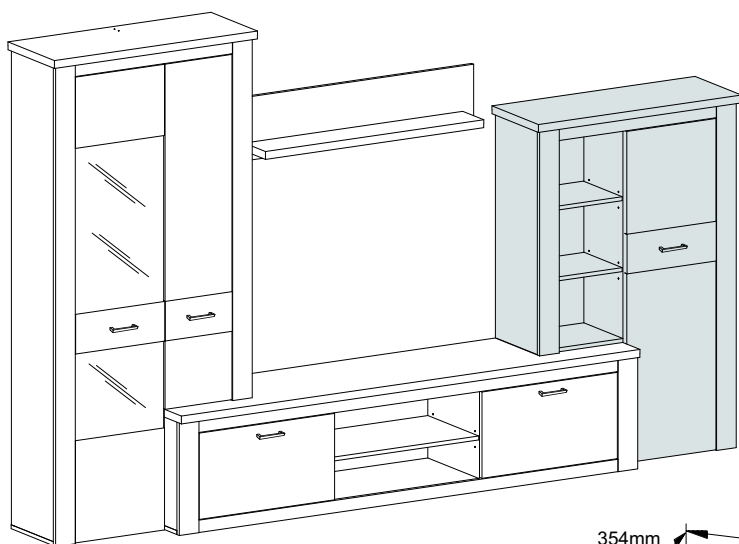
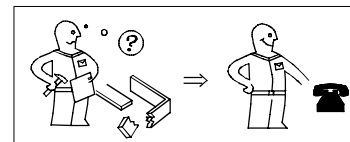
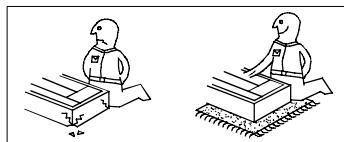
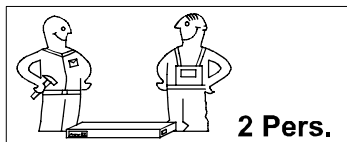
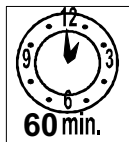
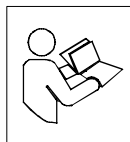

festziehen / tighten / Затягнете / serrer / stringere / utáhnout / vasttrekken / zategnuti / strángere / zwiázac / zacisnąc / szorosan meghúzni / pevne dotiahnut / trdno pritegniti / затянуть / dra ít



eindrücken / press in / enfoncer / wcisnąc / ribattere / zatlačit / Вкарайте / indrukken / benyomni / stlačit / vtisniti / tryck in / introducere prin apă sare / вдвигать



ausmessen / measure / mesurer / misurare / opmeten / izmeriti / miara / kimérni / izmeriti / măsurare / измерить / změřit / Измерете / mät upp / zmierzyc



drücken / press / presser / stisknout / Натиснете / vtisniti / nasinac / drukken / pritisnuti / nacisnac / pritisniti / нажать / (meg)nyomni / apasare / tryck fast / nacisnąc



einschlagen / hammer in / bevorni / sla in / frapper au marteau / infossare / Zabit' / zarazit / Набийте / zabiti / wbić / introducere prin bătaie / забить / zatlouct



Drehen - wenden / przekrećić - odwrócić / Keren - omdraaien / Girare - Ruotare / Okrenuti - ubnuti / Retourner - renverser / Turn over - turn around / Oblocte - obratite / Zавъртете - обвъртете / Obrnite list / Intoarceți - rotiți / Vrid runt - vänd / прокрутить - повернуть / otočit - obrátit / elforgatni - megfordítani

Modellname / Model name / Nom du modele / Modellnamn
 Nome modello / Název modelu / Modelnaam / Ime modela
 Numéro Modelo / Modell neve / Название модели /
 Názov modelu / Ime modela / Denumire model /
 Наименование на модела / Nazwa modelu

Modellnummer / Number / Numéro du modele
 Numero / Номер на модела / modello
 Číslo modelu / Modell száma / Eíslo modelu
 Številka modela / Număr model / Broj modela
 Modelnummer / Numer modelu

Type / Tipo / Típus / Typ / Тип / Tip

ПЕНАЛ 1Д

МОНТРЕАЛ

D Unser Direktservice für Beschlagteile
 Sollte Ihnen ein Beschlagteil fehlen, können Sie diese Servicekarte direkt an die untenstehende Adresse mailen. Wir können allerdings nur Beschlagteile auf diesem Wege verschicken. Sollten Sie eine andere Beanstandung an Ihrem Möbelstück haben, so wenden Sie sich bitte direkt an Ihr Möbelhaus.

GB Our direct order service for fitting
 If a fitting part is missing, you can e-mail this service card directly to the address below. However, we can only send fitting parts in this way. If you have any other cause for complaint concerning your item of furniture, please contact your furniture store directly.

CZ Naše přímé služby pro kování
 Chybí-li vám nějaký díl z kování, můžete tuto servisní kartu odeslat e-mailem přímo na níže uvedenou adresu. Touto cestou však můžeme rozesílat jen díly kování. Pokud byste reklamovali jiný díl nábytku, obraťte se přímo na svého prodejce nábytku.

F Bien étudier la notice de montage
 S'il vous manque une ferrure, veuillez envoyer directement la présente carte service à l'adresse e-mail indiquée ci-dessous. Cependant, ceci nous permet uniquement d'envoyer des ferrures. Pour tout autre type de réclamation concernant votre meuble, veuillez contacter directement votre magasin d'ameublement.

I Il nostro servizio diretto per l'ordine della ferramenta
 Qualora Vi dovesse mancare un pezzo di fissaggio, allora Vi preghiamo di inviare questa carta di servizio immediatamente all'indirizzo sottostante. Possiamo inviare i pezzi di fissaggio solamente per mezzo di questo procedimento. Qualora dovete avere qualche altra reclamazione in merito al mobile, allora Vi preghiamo di rivolgerVi direttamente al Vostro Negozio di mobili.

BG Нашата директна услуга за обков
 Ако липсват части от комплекта, полъзнете настоящата сервисна карта и ни я изпратете на e-mail адреса, посочен по-долу. По този начин можем да доставяме само липсващи елементи от обкова. Ако установите други дефекти по мебелите, Ви съветваме да се обърнете към мебелната къща/магазин, от който сте закупили стоката.

NL Onze directservice voor losse onderdelen
 Wanneer er een onderdeel ontbreekt, kunt u deze servicekaart direct aan onderstaand e-mailadres sturen. Wij kunnen langs deze weg echter alleen beslagdelen versturen. Mocht u een ander probleem aan uw meubel hebben, verzoeken wij u contact op te nemen met uw meubeldealer.

PL Nasz bezpośredni serwis części montażowych
 Jeżeli brakuje części koniecznych do montażu, prosimy o przesłanie nam niniejszej karty serwisowej na niżej podany adres e-mailowy. W ten sposób możemy przesyłać Państwu tylko brakujące części. W przypadku innych reklamacji dotyczących mebla, prosimy zgłosić się do salonu meblowego, w którym został dokonany zakup.

HR Servis za okove
 U slučaju da nedostaje neki od dijelova molimo vas da na dolje navedenu mail adresu pošaljete ovaj servisni obrazac. Na ovaj način mogu se dostaviti samo okovi. U slučaju da imate dodatne prigovore vezane uz komad namještaja molimo vas da se obratite izravno trgovini namještaja gdje je isti kupljen.

HU Direktszolgáltatunk vasalatok esetén
 Ha hiányzik egy vasalat, ezt a kártyát közvetlenül elküldheti az alábbi tárfelhátó címre. Azonban csak vasalatoskat tudunk így küldeni. Amennyiben másfajta reklamáció áll fenn bútordarabját illetően, forduljon közvetlenül a bútoráruházhoz.

SK Náš priamy servis pre časti kovania
 Ak by Vám chýbala nejaká časť kovania, môžete poslať túto servisnú kartu poslať e-mailom na nižšie uvedenú adresu. Diely kovania vieme poslať iba týmto spôsobom. Ak by ste mali inú reklamáciu ohľadom Vášho nábytku, obráťte sa priamo na Vašu predajňu nábytku.

SLO Naše direktno uslužne storitve za okovje
 Če vam manjka kakšno okovje, lahko to servisno kartico pošljete po e-pošti direktno na spodnji naslov. Po tej poti vam lahko pošljemo samo okovje. Če želite reklamirati kakšen drug del pohištva, se obrnite neposredno na vašo trgovino pohištva.

RO Service-ul nostru direct pentru feronerie
 În cazul în care vă lipsește o piesă de feronerie puteți să trimiteți direct acest card de service prin e-mail la adresa de mai jos. Noi nu putem expedia piese de feronerie decât pe această cale. Dacă aveți o altă reclamație referitoare la piesa de mobilier, atunci vă rugăm să vă adresați direct la magazinul dvs. de mobilă.

RUS Наш прямой сервис для поставок фурнитуры
 Если окажется, что Вам не хватает того или иного элемента фурнитуры, Вы можете отправить сервисную карту по факсу непосредственно на нижеприведенный адрес электронной почты. Однако, таким образом мы можем пересылать лишь фурнитуру. Если же у Вас возникнут иные претензии относительно приобретенной мебели, пожалуйста, обращайтесь непосредственно в организацию, осуществившую продажу.

S Vår direktservice för beslagsdelar
 Om du saknar en beslagsdel kan du skicka detta servicekort direkt till e-postadressen som anges nedan. Tänk på att detta är den enda möjligheten att skicka beslagsdelar till dig. Om du vill reklamera din möbel av en annan anledning måste du kontakta ditt möbelhus direkt.

ES Nuestro servicio directo para accesorios
 Si le falta algún accesorio, puede enviar esta tarjeta de servicio directamente a la siguiente dirección. No obstante, por este método solo podemos enviar accesorios. Si tiene alguna otra objeción sobre su mueble, consulte directamente con su mueblería.

TR Donatılar için doğrudan servisimiz
 Bir donatınız eksikse bu servis kartını doğrudan aşağıda bulunan adrese doğrudan mail yazabilirsiniz. Sadece bu yolla donatılar gönderilebilir. Mobilyanızda başka şikayetleriniz varsa lütfen doğrudan mobilya satıcınıza danışın.

max.

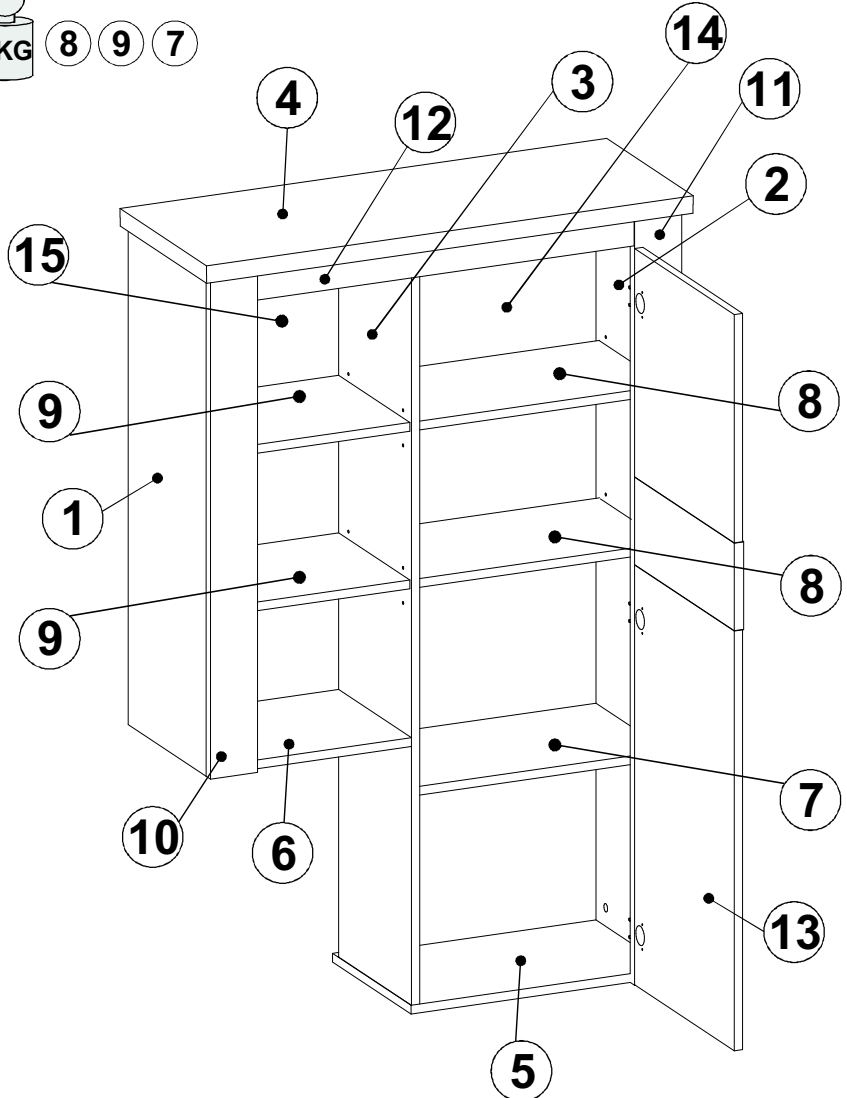
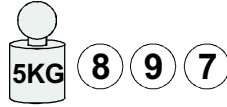

C 1/1

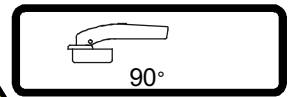

B3

Modellname / Model name / Nom du modele / Modellnamn / Nome modello / Název modelu / Modelnaam / Ime modela / Numéro Modelo / Modell neve / Название модели / Názov modelu / Ime modela / Denumire model / Наименование на модела / Nazwa modelu

Modellnummer / Number / Numéro du modele / Numero / Номер на модела / modello / Číslo modelu / Modell száma / Eíslo modelu / Številka modela / Număr model / Broj modela / Modelnummer / Numer modelu

Type / Типо / Típus / Тип / Тип / Tip

ПЕНАЛ 1Д

МОНТРЕАЛ

B1

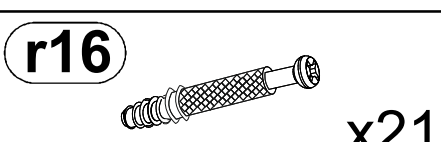
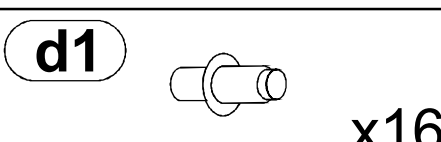
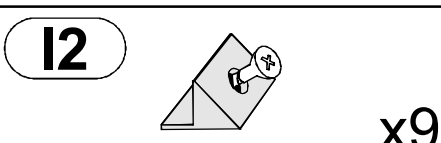
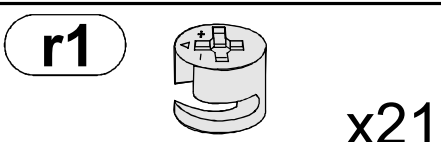
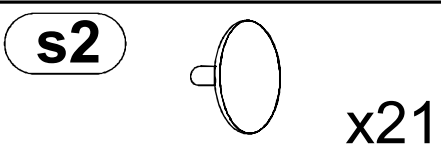
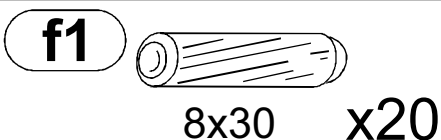

B2

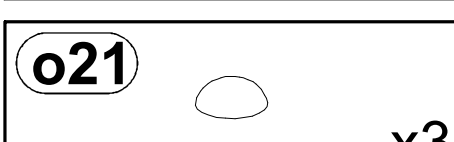
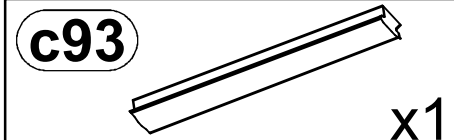

B3

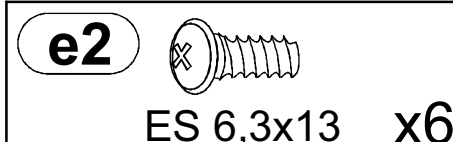
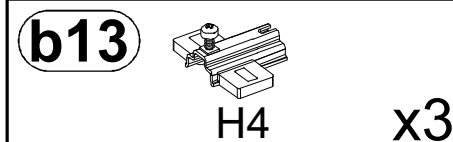
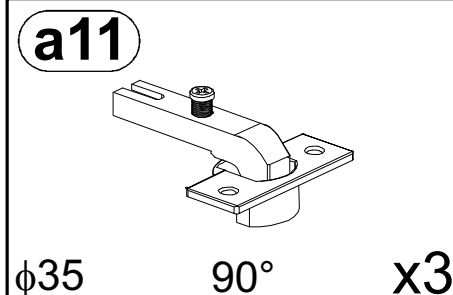

B4

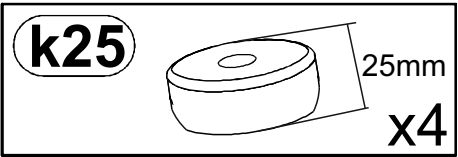
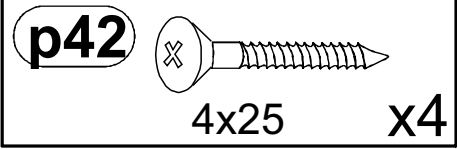

B5

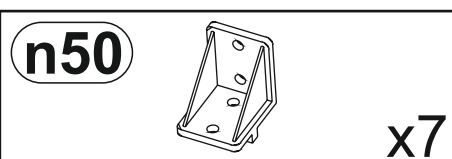
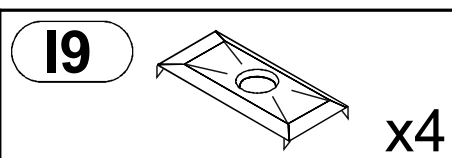
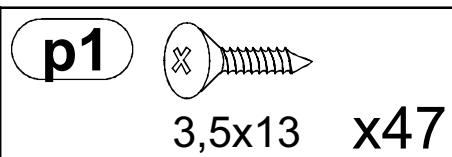
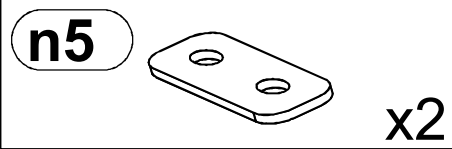

B6

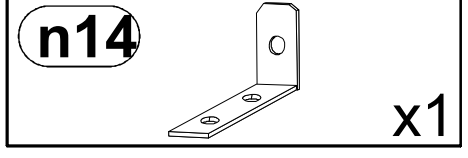
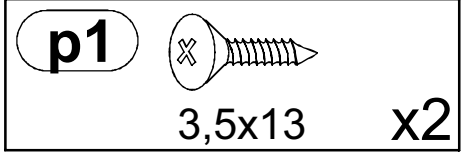
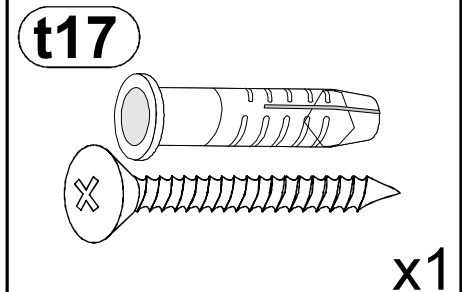

1

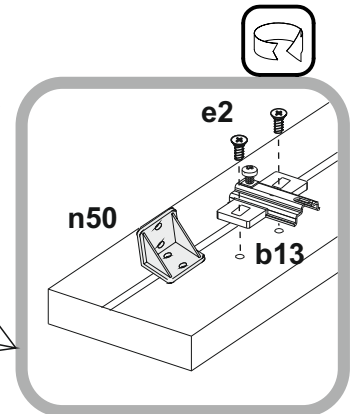
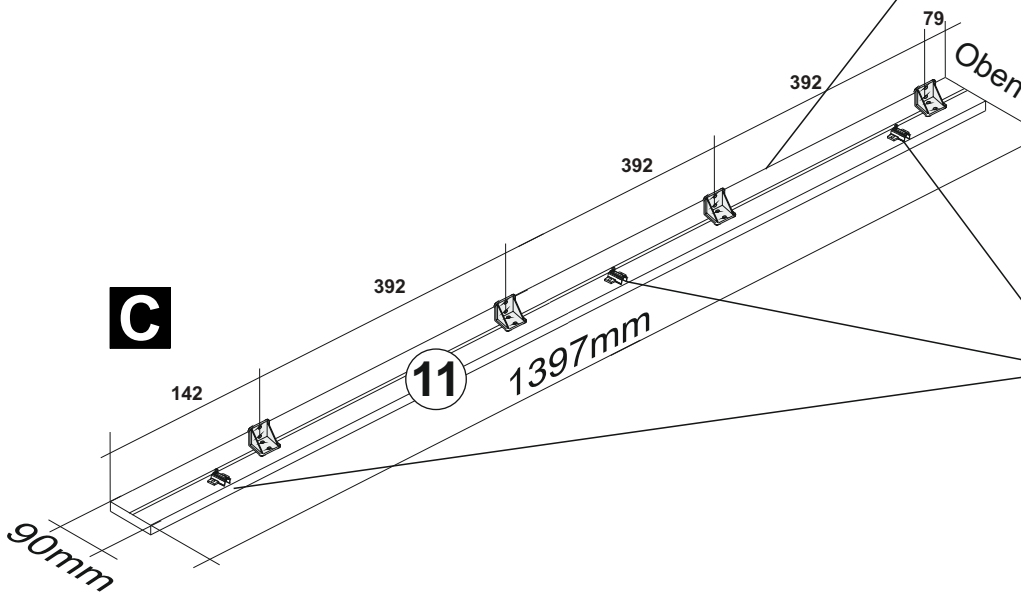
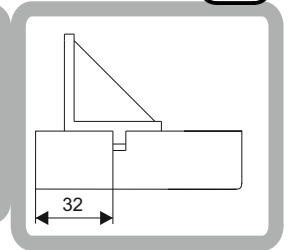
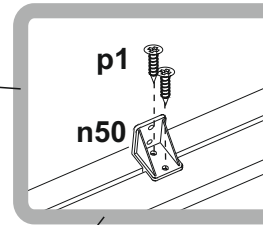
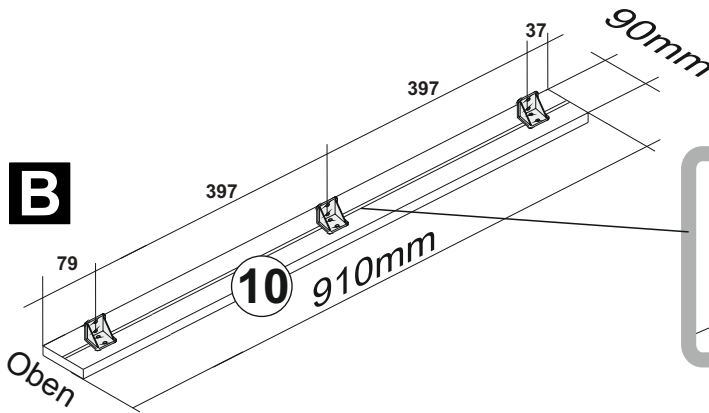
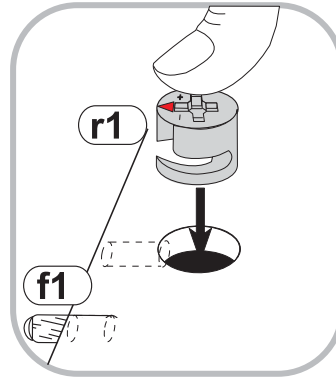
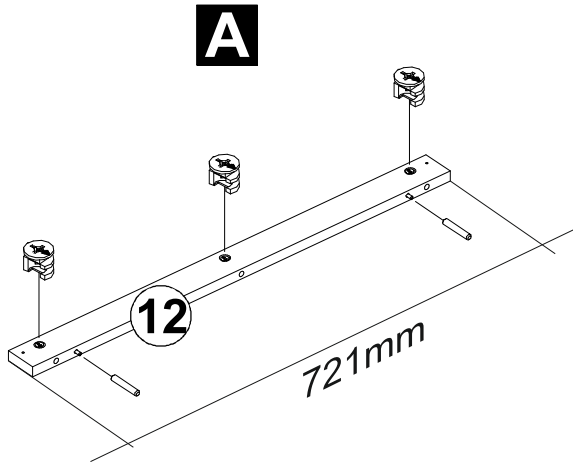
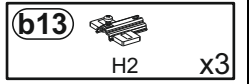
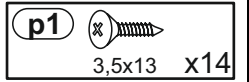
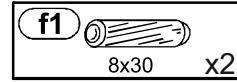
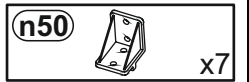
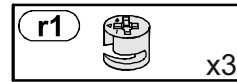
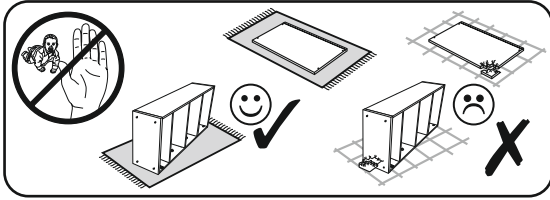

2

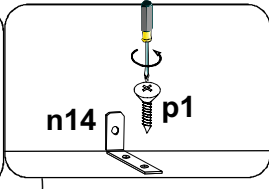
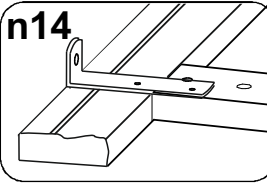

A

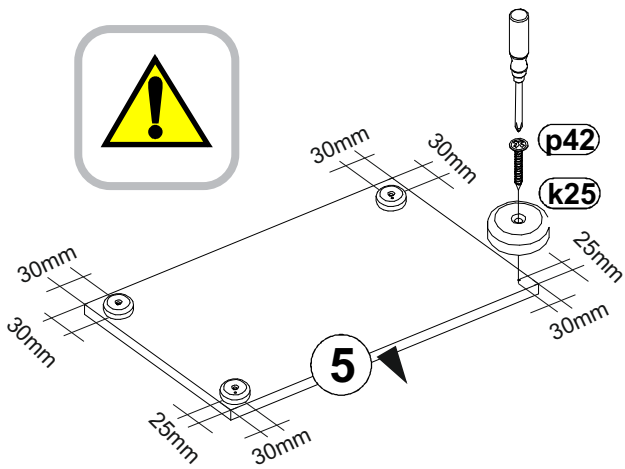
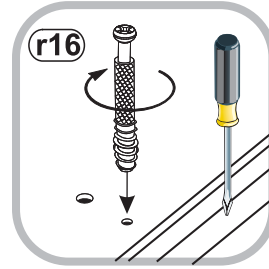
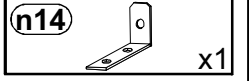
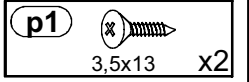
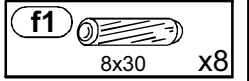
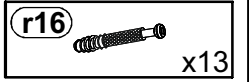
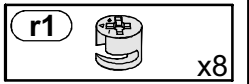
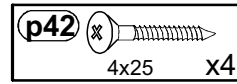
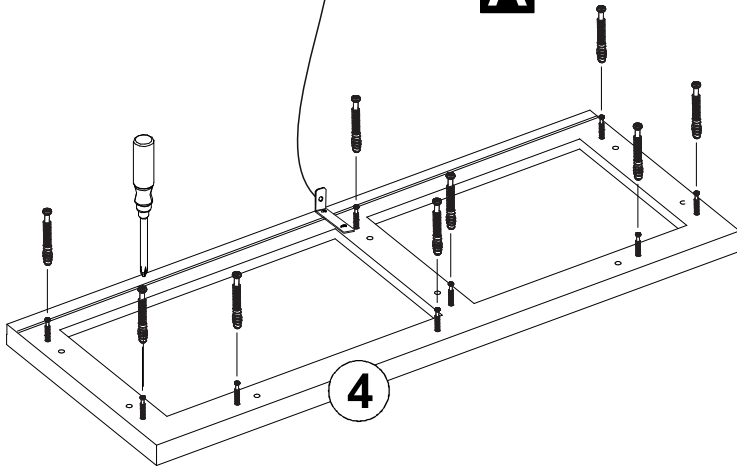

B

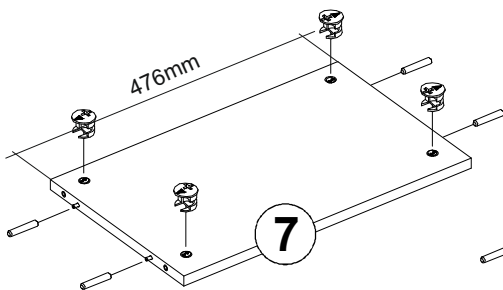
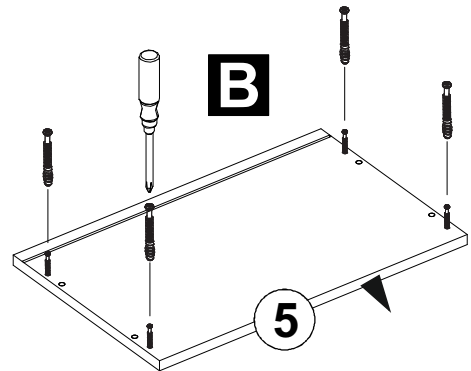

C

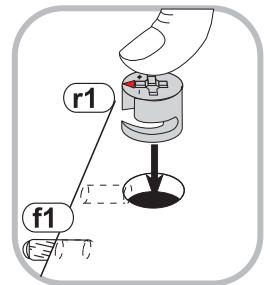
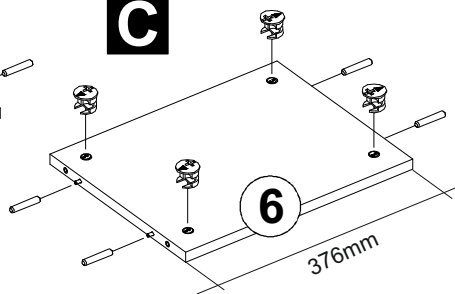

3

r1  x10

r16  x8

f1  8x30 x10

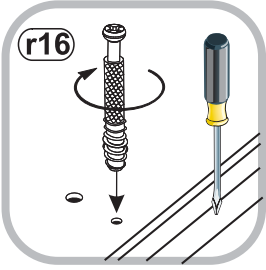

A

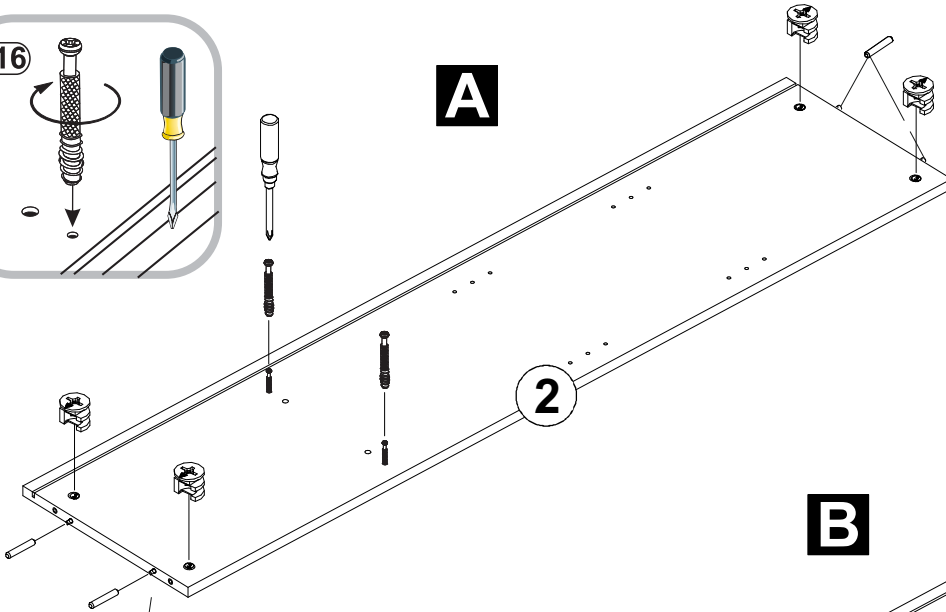

B

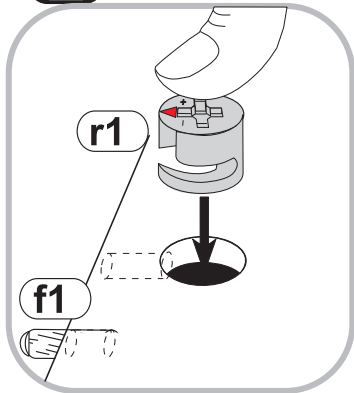
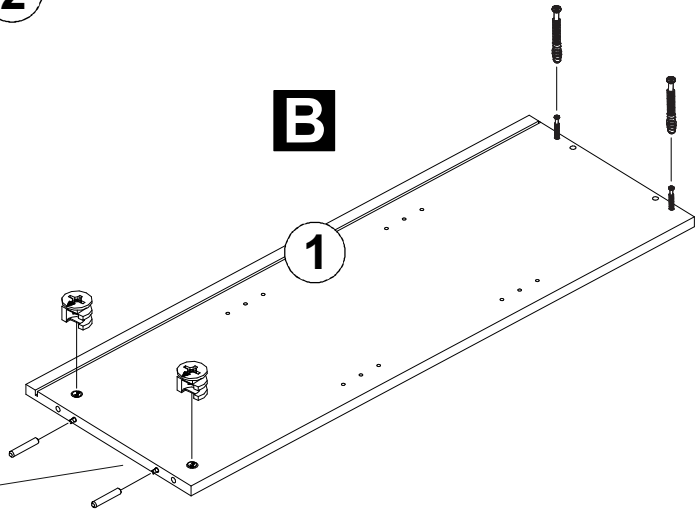

C

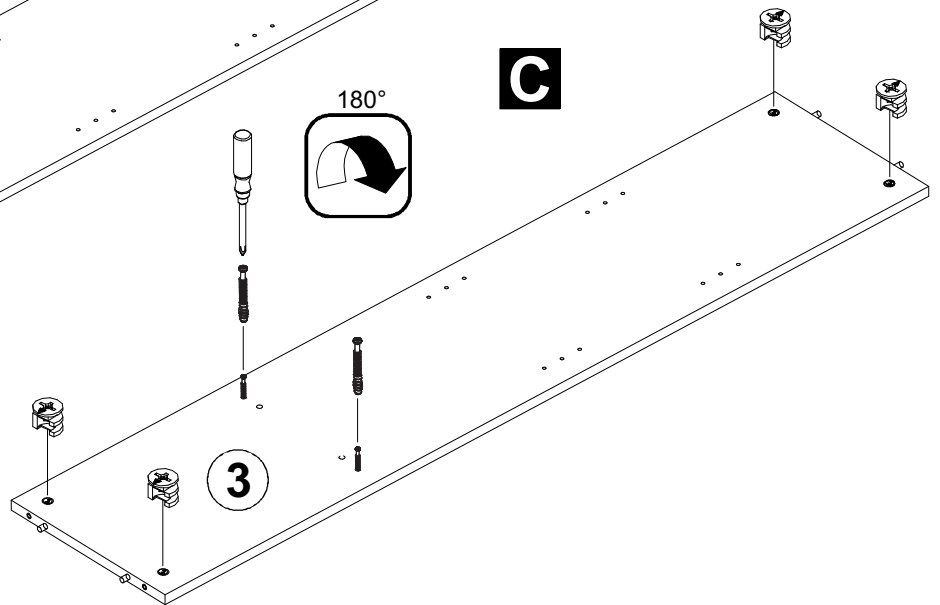
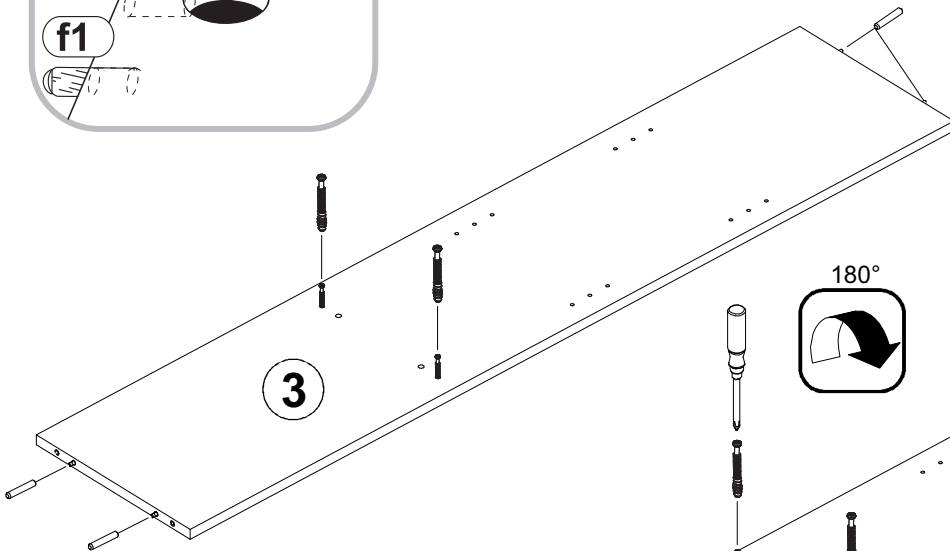

4

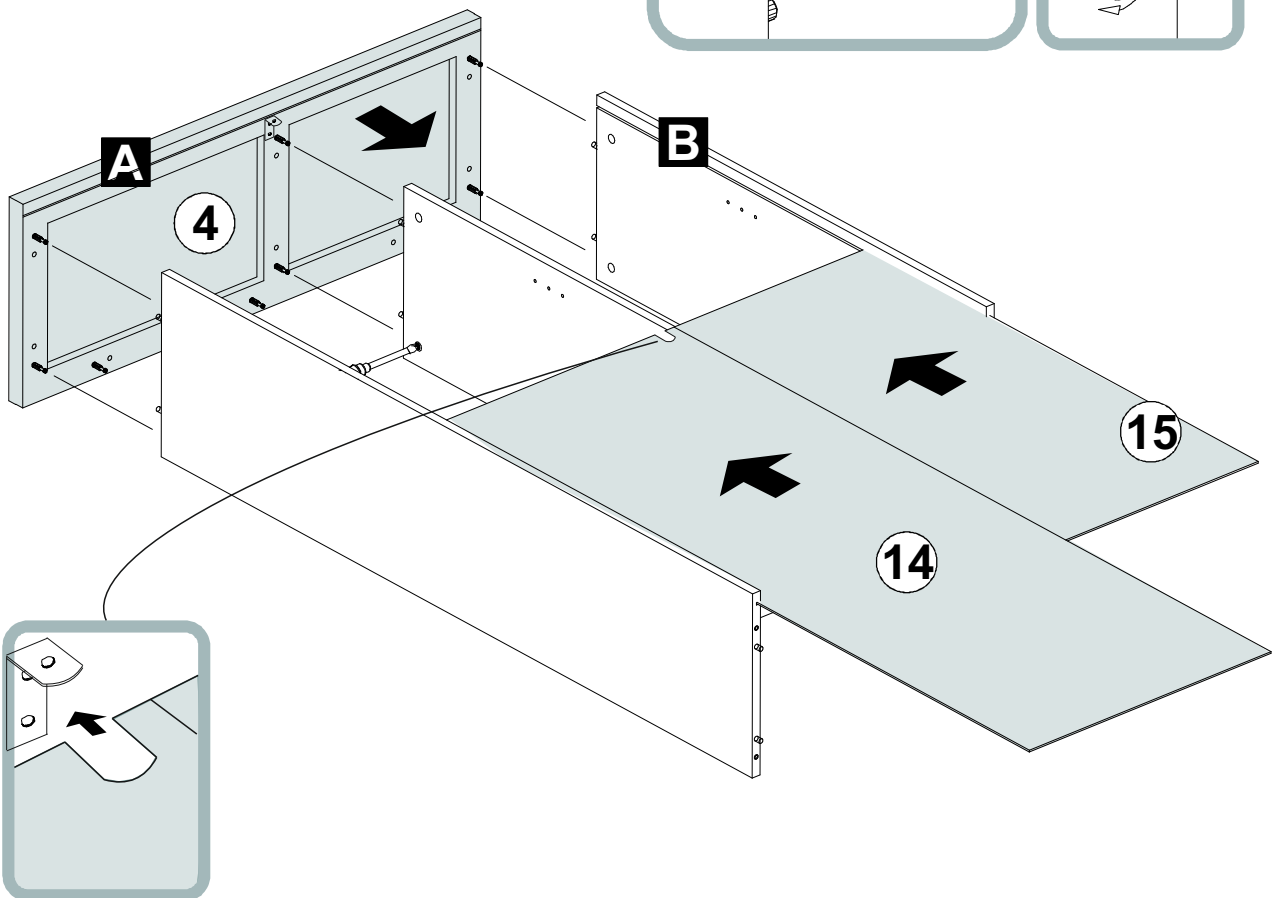
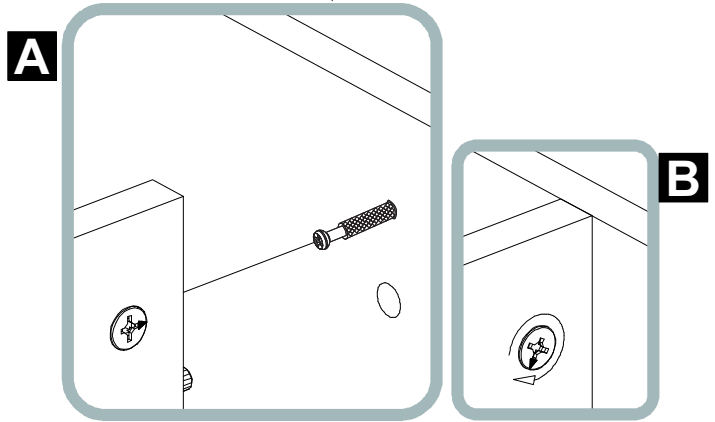
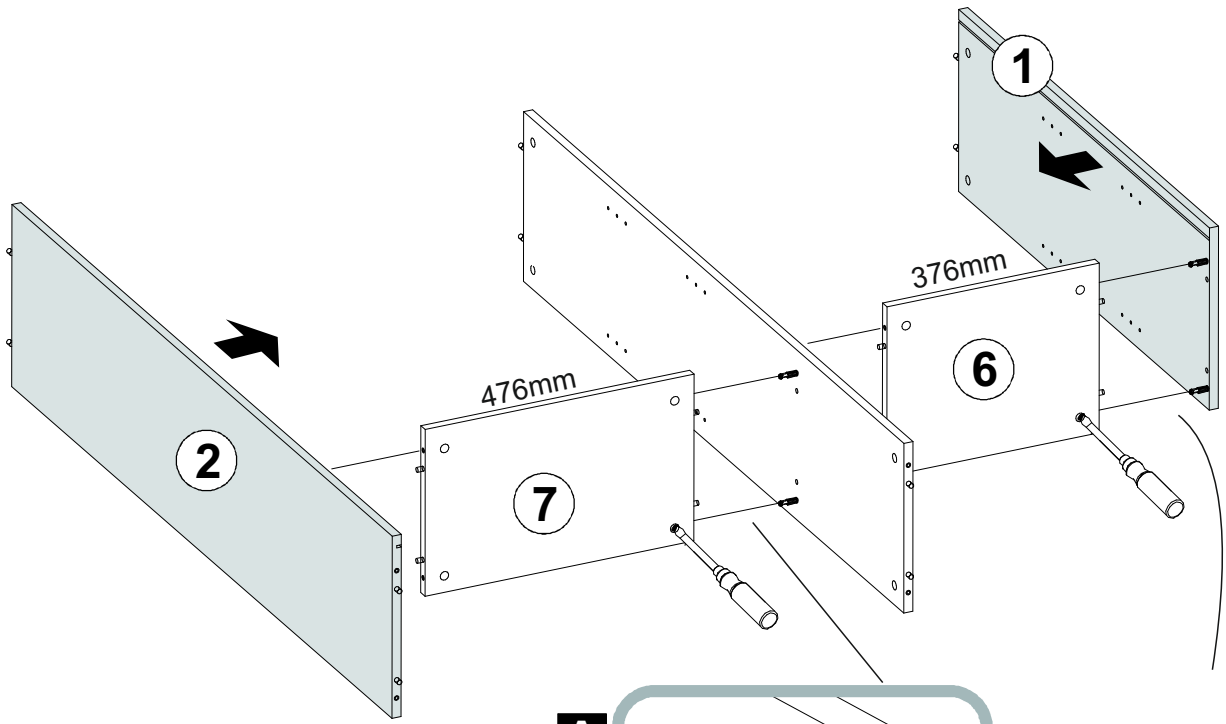

5

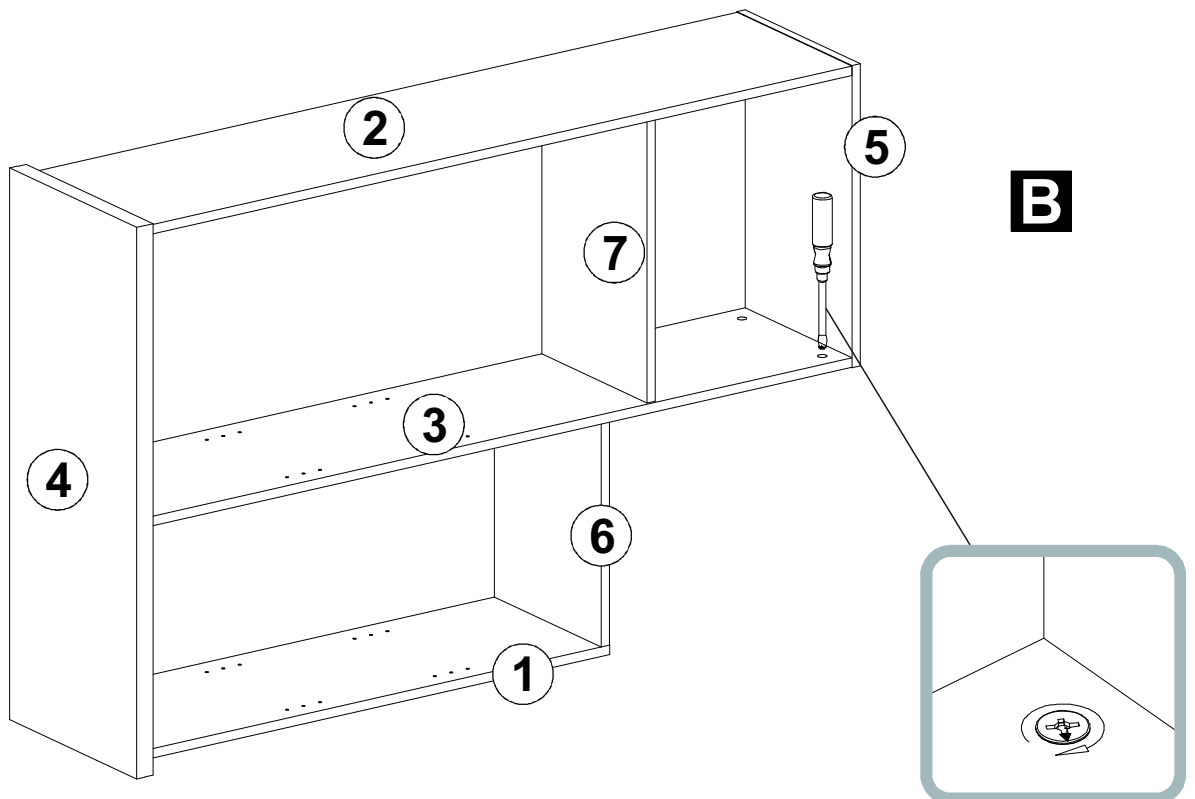
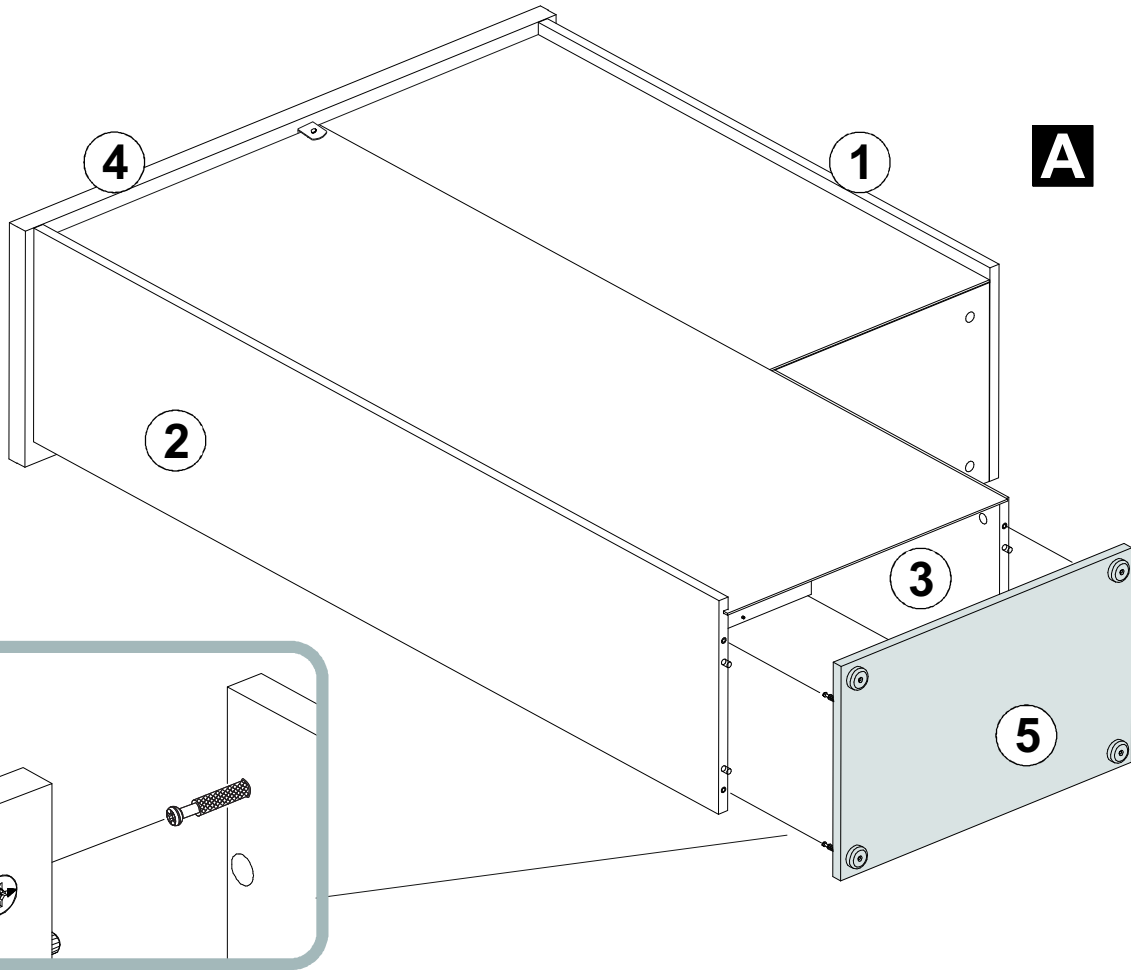

6

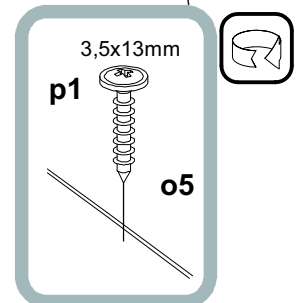
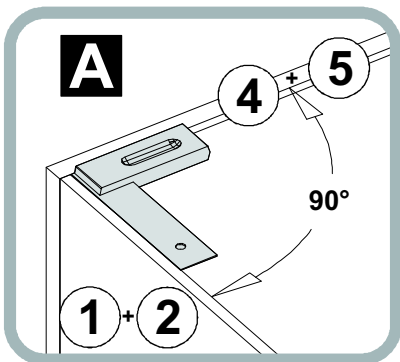
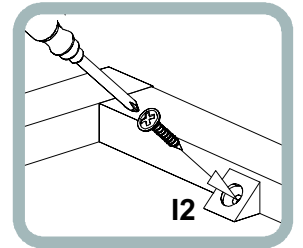
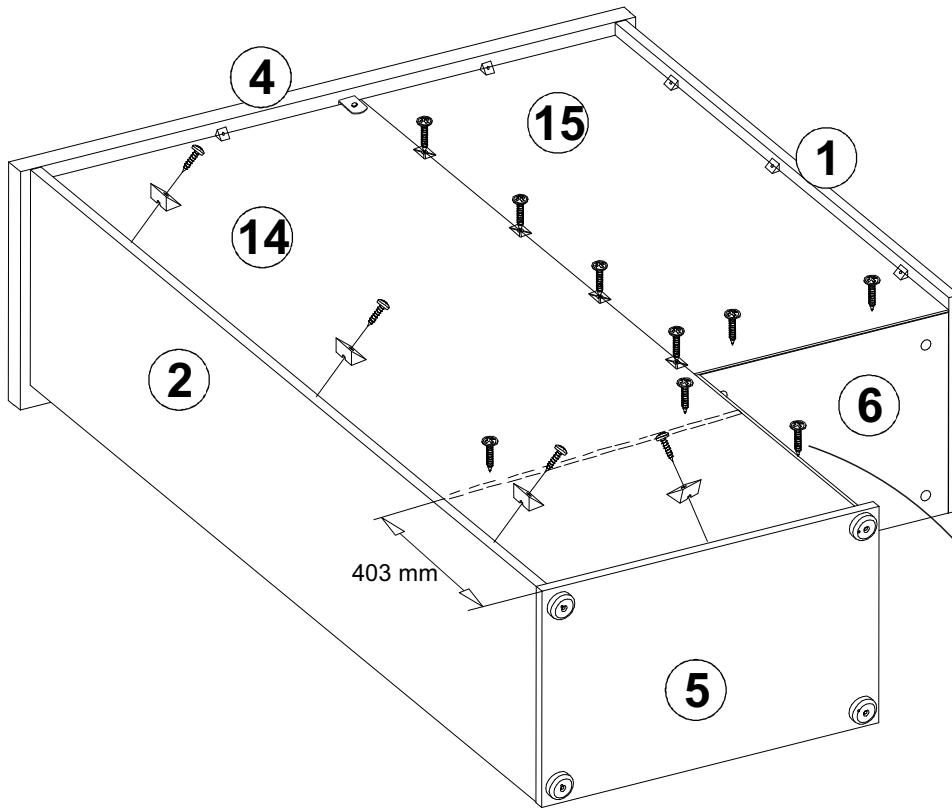
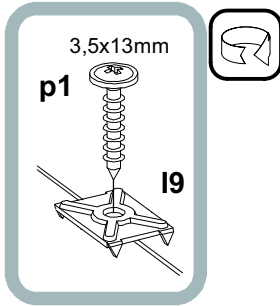
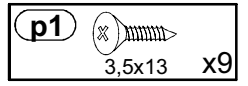
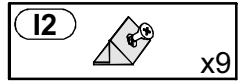
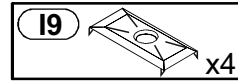

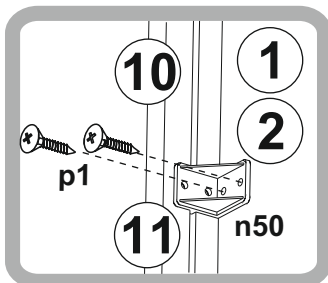
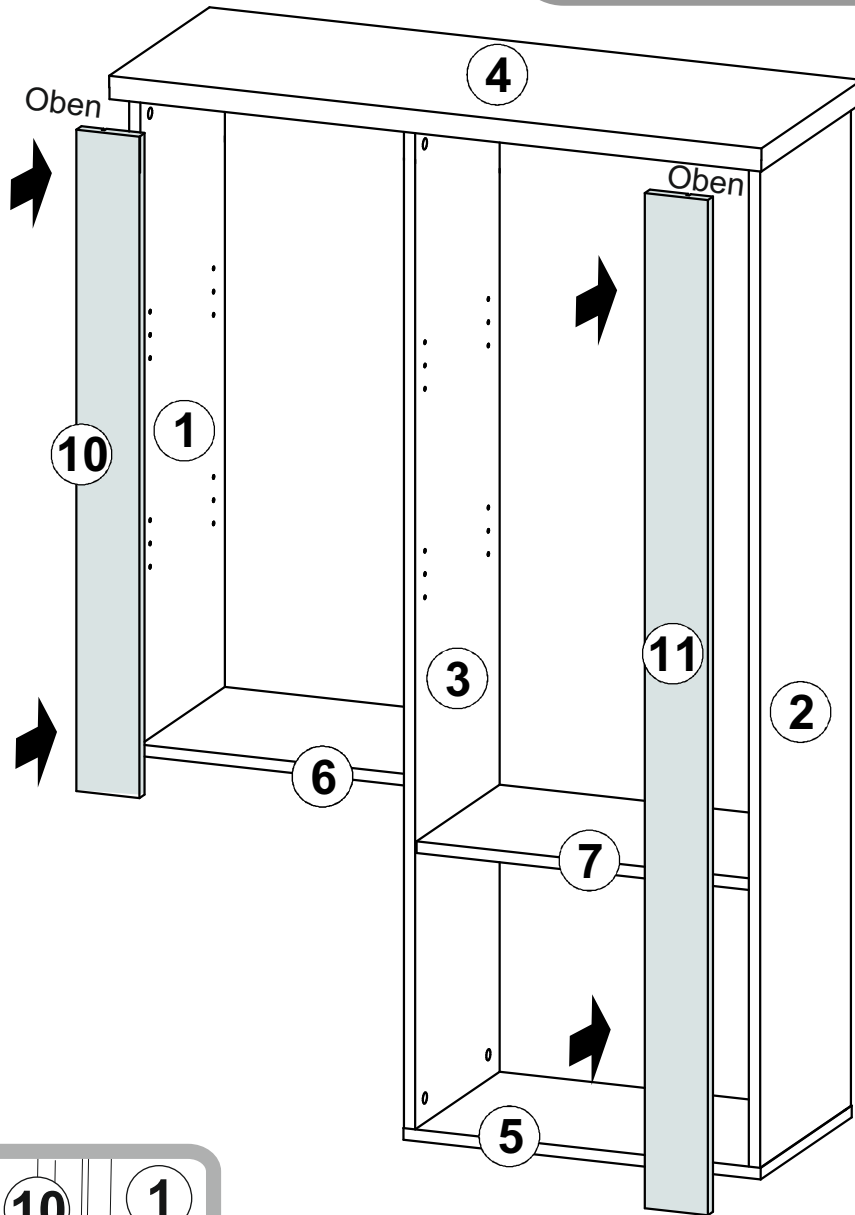
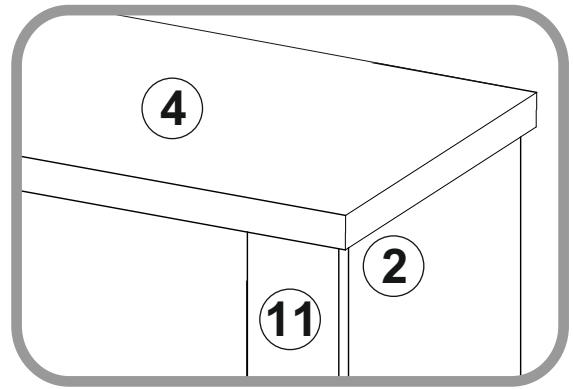

8

A

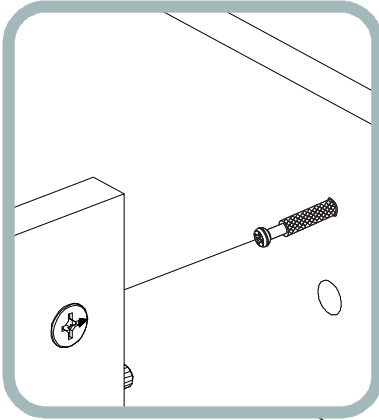

B

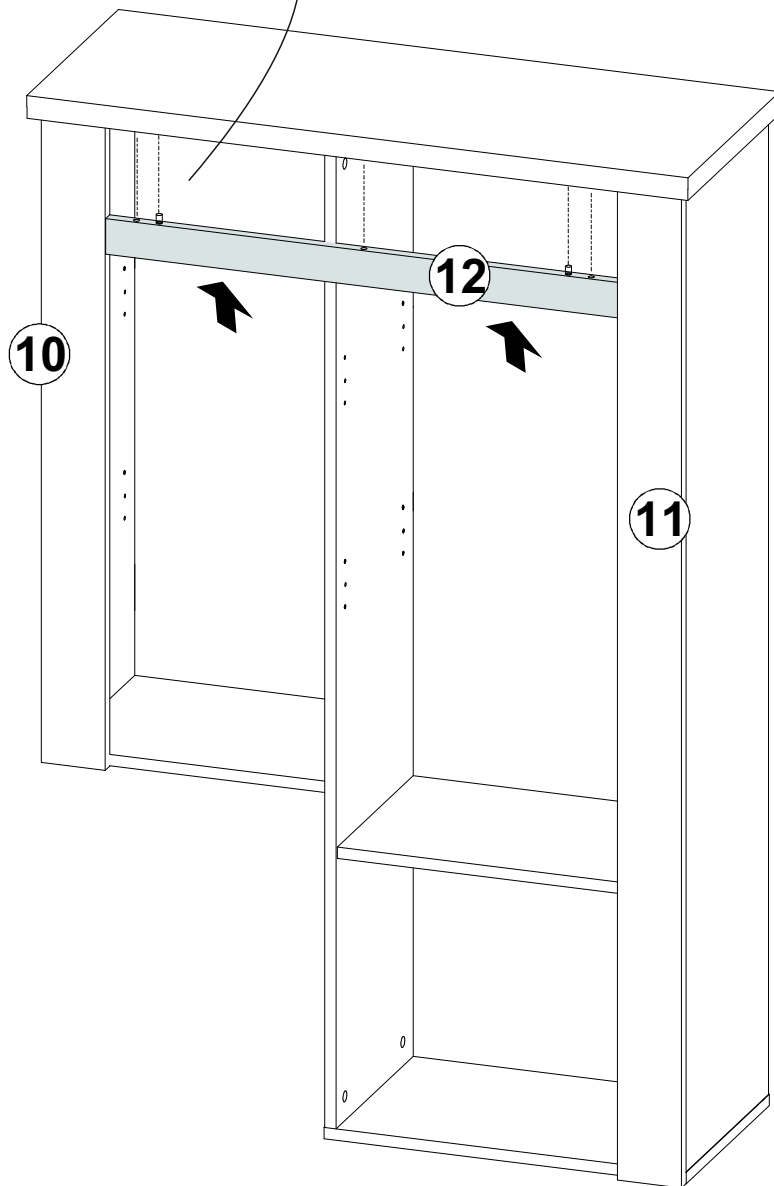
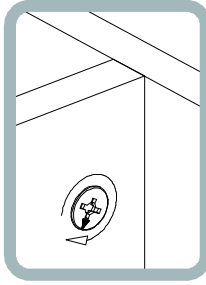

9

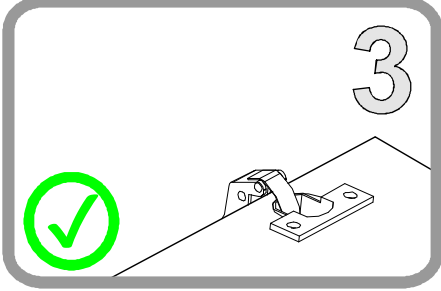
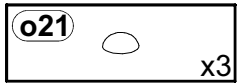
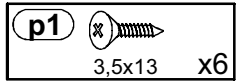
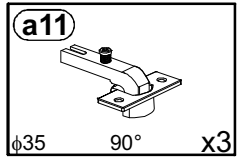
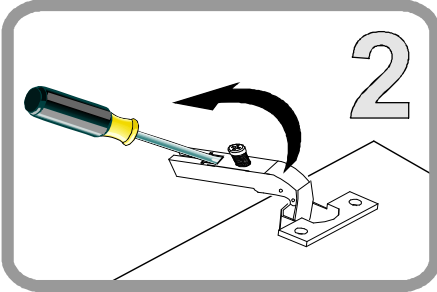
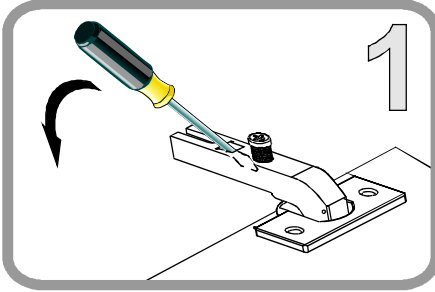

A

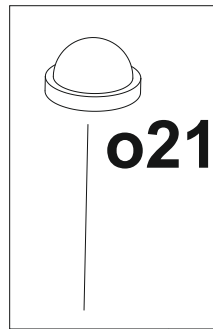

o21

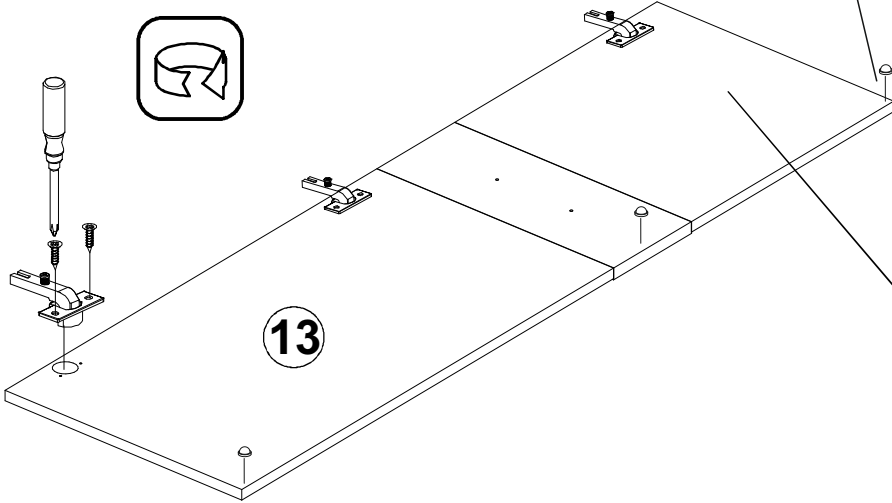
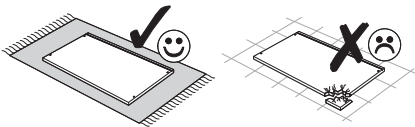

13

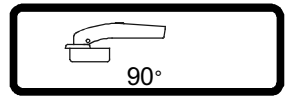

B3

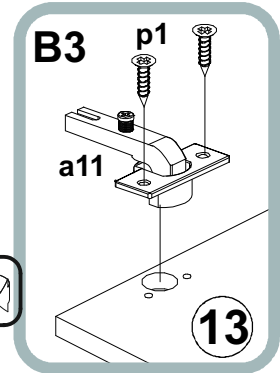

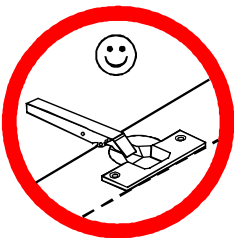

13



10

p1  3,5x13 x4

n5  x2

d1  x16

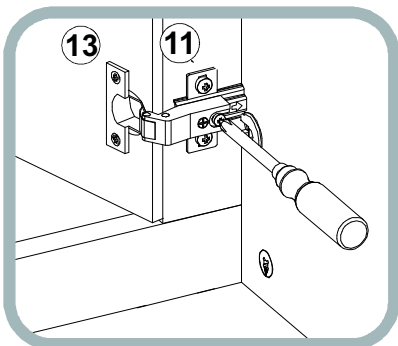
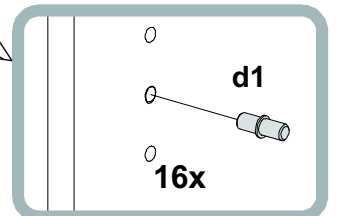
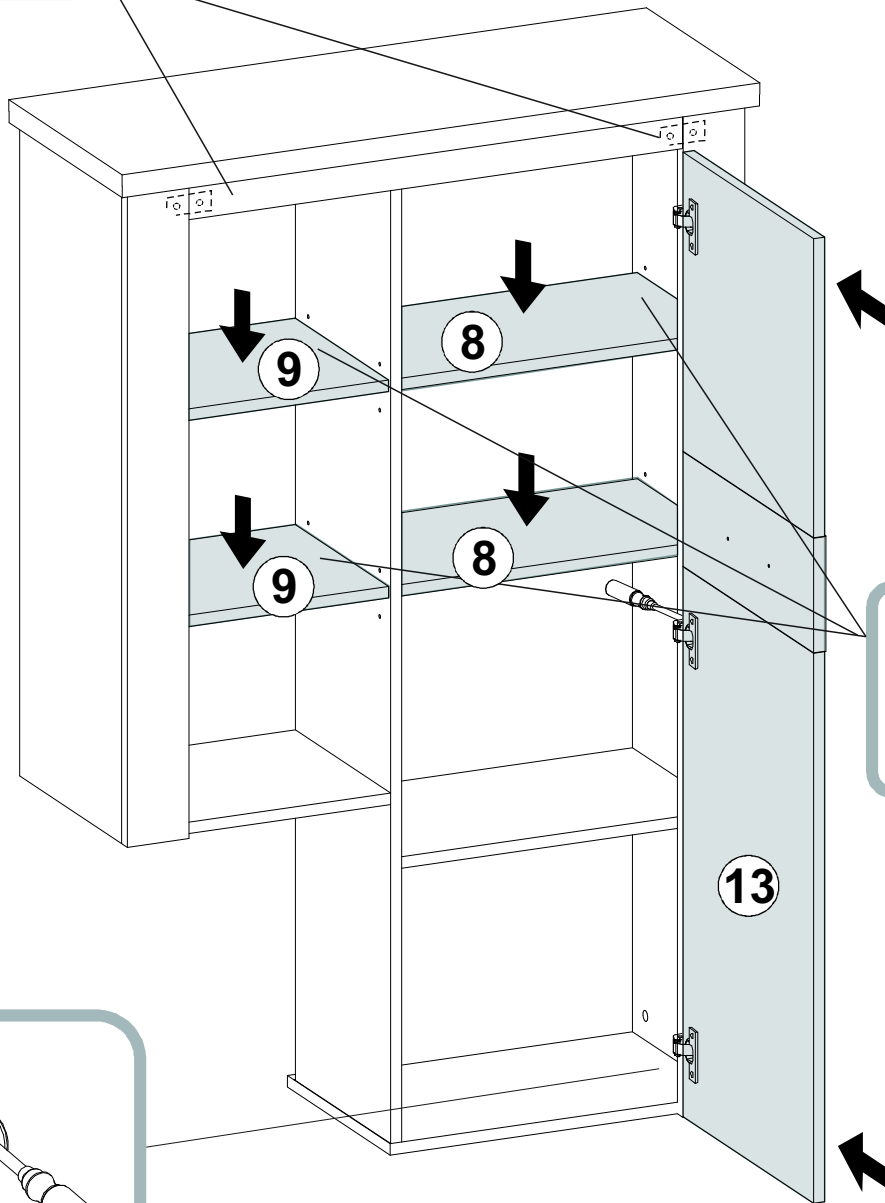
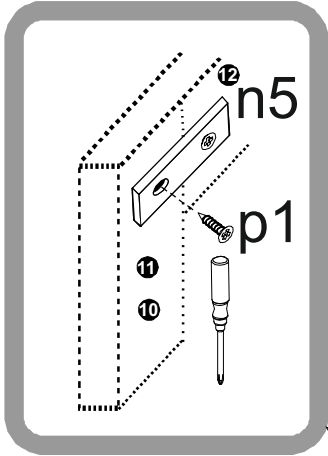

11

